

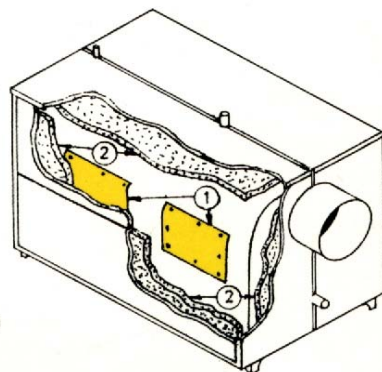

Caldeira Argus

CALDEIRAS ARGUS

Cald. Tipo	Poten. Kcal/h	Alt. (A) mm	Comp (B) mm	Larg. (C) mm	Ø Saída Fumo (D) mm	Saída Fumo €mm	Alt. Saída Fumo (F) mm	Vol. Ltos	Peso Aprox Kg	Ø Forma mm	Comp Forma mm	Comp Porta Aber. mm	Reg. Aut. Temp. (G) Ø	Saída Fluido (J) Ø	Retor Fluido (L) Ø	Tê P/ CHAM. C/ 5.00			
																Ø mm M	Ø mm N	mm O	mm P
A 20	20000	870	780	710	230	160	700	30	244	400	545	1310	3/4"	1 1/2"	1 1/2"	235	235	397	500
A 30	30000	870	1120	710	230	160	700	43	313	400	829	1600	3/4"	1 1/2"	1 1/2"	235	235	397	500
A 40	40000	870	1370	710	230	160	700	53	366	400	1080	1850	3/4"	1 1/2"	1 1/2"	235	235	397	500
A 50	50000	1120	1190	970	230	160	930	83	552	640	900	1936	3/4"	1 1/2"	1 1/2"	235	285	423	500
A 60	60000	1120	1290	970	230	160	930	100	600	640	1000	2096	3/4"	2"	2"	235	285	423	500
A 70	70000	1120	1600	970	230	160	930	110	695	640	1250	2345	3/4"	2"	2"	235	285	423	500
A 80	80000	1120	1700	970	280	160	930	120	797	640	1400	2439	3/4"	2"	2"	285	320	440	500
A 100	100000	1370	1410	1130	280	160	1155	130	900	800	1100	2030	3/4"	2"	2"	285	320	440	500
A 120	120000	1370	1550	1130	280	160	1155	142	1042	800	1250	2476	3/4"	3"	3"	285	380	470	500
A 140	140000	1370	1700	1130	300	160	1145	155	1190	800	1450	2726	3/4"	3"	3"	300	420	490	500

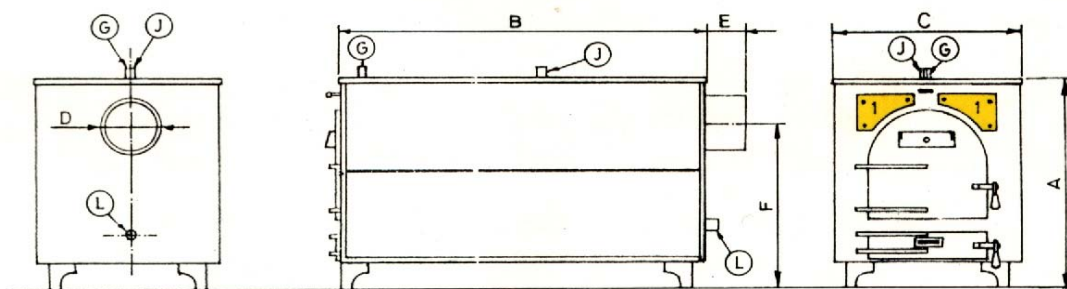

LEGENDA:
 1 - Zona de limpeza
 2 - Isolamento

